

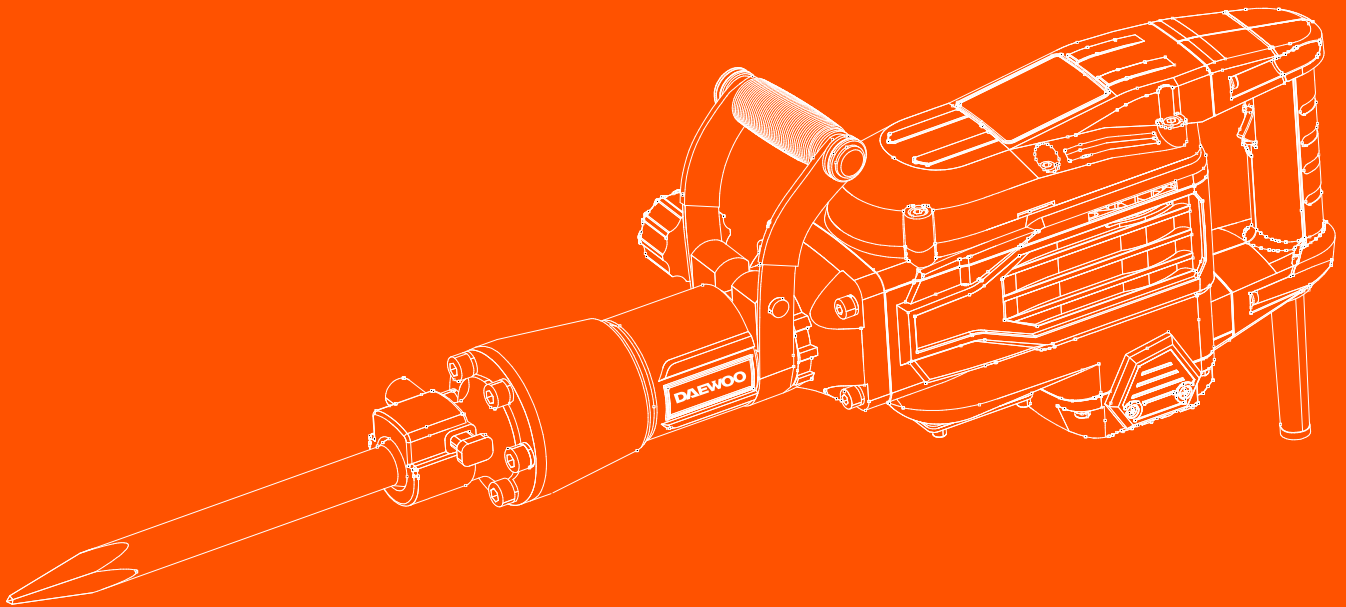

DAEWOO
POWER PRODUCTS

DADH30B
DEMOLITION HAMMER



USER'S MANUAL

www.daewoopowerproducts.com

Manufactured under license of Daewoo International Corporation, Korea

INDEX

1.PARTS LIST	2
2.GENERAL SAFETY RULES	3
3.TECHNICAL CHARACTERISTICS	6
4.MAINTENANCE	6
5.ASSEMBLY	7
WARRANTY	9

1. PARTS LIST

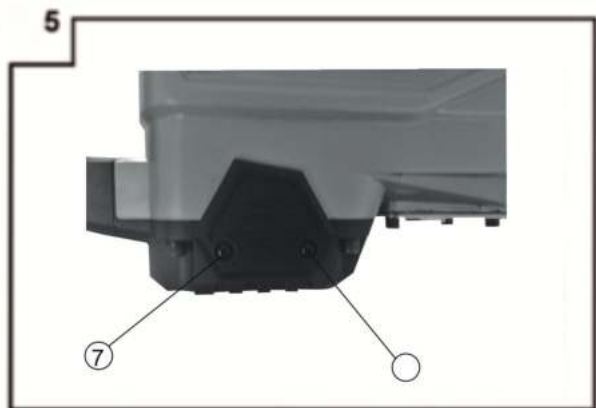
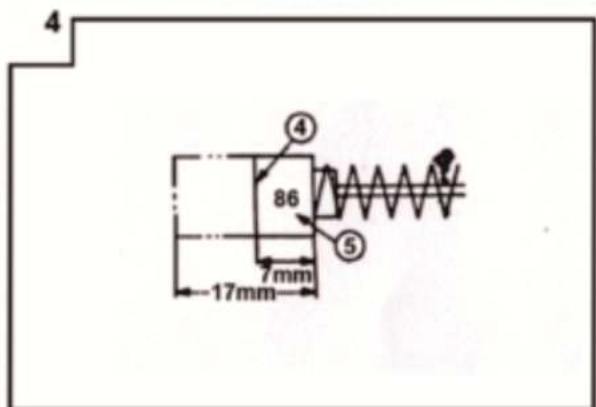
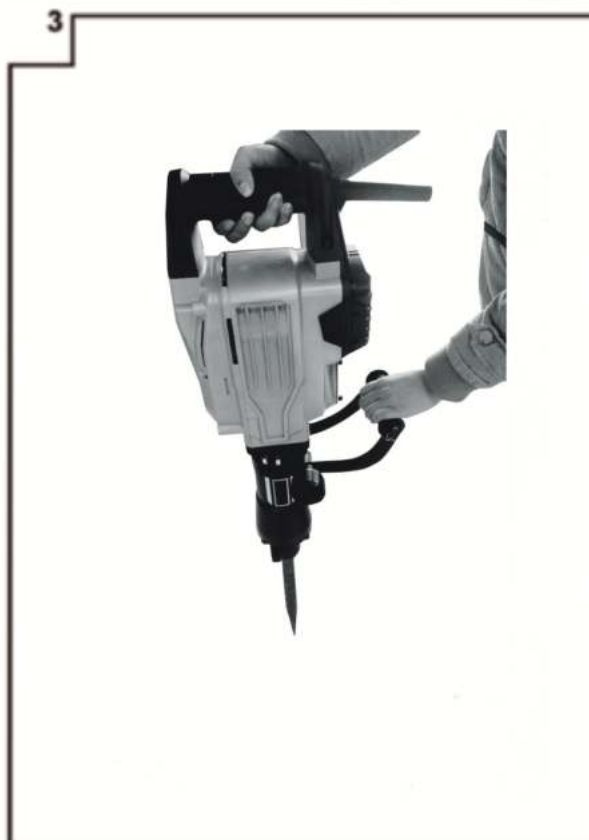
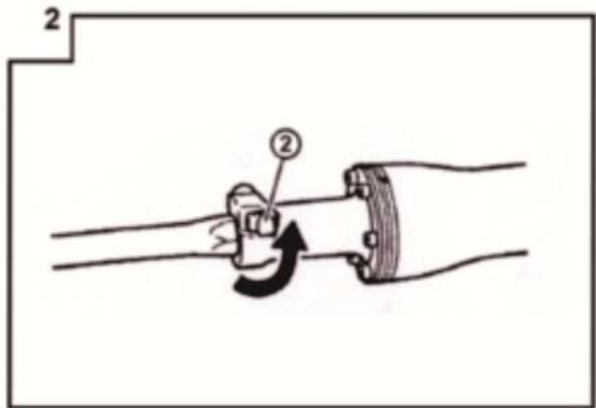
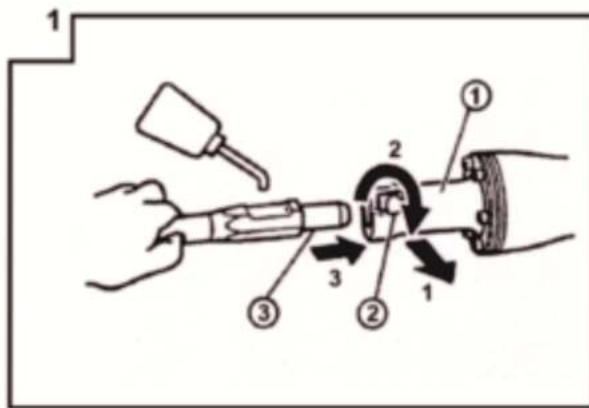

①	Front cover	
②	Stop lever	
③	Tool shank	
④	Wear limit	
⑤	No. of carbon brush	
⑥	Cap cover	
⑦	Nylock Hex.Socket Hd.Bolt ST3.9X12	

Important: carefully read the instructions in this manual as well as the general safety instructions before using this tool.

Keep these manuals for further reference.

Accessories:

- 1 Brush
- 1 Thin spanner
- 2 Male key
- 1 Pot of lubricant
- 1 Pointed chisel
- 1 Flat chisel

The tool should be connected to a power source connected to earth.

If your installation needs an extension, make sure it is equipped with an earth plug.



Wearing of protection goggles advised

Wearing of protection against noise advised

Wearing of protective shoes advised

Wearing of respiratory protection advised

This tool is designed to break, scale, drive...concrete or similar materials. For example the installation of tubes, cables, washroom facilities of draining, and other civil engineering works. correctly lit.

4. Store the tool in a dry place, far from sources of heat or of dangerous vapors (ideal: 10 to 15 °C). Do not operate your tool near explosive or inflammable materials.
5. Work with tools in good condition and adapted to the task to undertake. This equipment should be used as such and should not be overloaded. The tool should always be used with its additional handle(B) and firmly held with both hands.
6. Before each use, check the oil level, the tightening of screws, the correct mounting of the drive spindle.
7. Make sure of not driving into live parts or gas or water pipes, etc. You would risk electrocution or an explosion. Detect any live or metallic parts before starting to work (for example, a live wire in a wall with a metals detector)
8. Do not try to open or dismantle the tool nor to intervene by yourself. Only a competent and specialized service can intervene in complete safety, by using original parts and the manufacturer's drawings.
9. Use auxiliary handles supplied with the tool.

2. GENERAL SAFETY RULES

WARNING! Read all instructions Failure to follow all instructions listed below may result in electric shock, fire and/or serious injury. The term "power tool" in all of the warnings listed below refers to your mains operated(corded)power tool or battery operated(cordless) power tools.

SAVE THESE INSTRUCTIONS

1) Work area

- a) Keep work area clean and well lit. Cluttered and dark areas invite accidents.
- b) Do not operate power tools in explosive atmospheres, such as in the presence of flammable liquids, gases or dust. Power tools create sparks which may ignite the dust or fumes.

2) Electrical safety

- a) Power tool plugs must match the outlet. Never modify the plug in any way. Do not Use any adapter plugs with earthed(grounded)power tools. Unmodified plugs and matching outlets will reduce risk of electric shock.
- b) Avoid body contact with earthed or grounded surfaces such as pipes, radiators, ranges and refrigerators. There is an increased risk of electric shock if your body is earthed or grounded.
- c) Do not expose power tools to rain or rain or wet conditions. Water entering a power tool will increase the risk of electric shock.
- d) Do not abuse the cord. Never use the cord for carrying, pulling or unplugging the power tool. Keep cord away from heat,oil,sharpedges or moving parts. Damaged or entangled cords increase the risk of electric shock.
- e) When operating a power tool outdoors, use an extension cord suitable for outdoor user educes reduces the risk of electric shock.

3) Personal safety

- a) Stay alert, watch what you are doing and use common sense when operating a power tool. Do not use a power tool while you are tired or under the influence of drugs, alcohol or medication. A moment of inattention while operating power tools may result in serious personal injuries.
- b) Use safety equipment. Always wear eye protection. Safety equipment such as dust mask, non-skid safety shoes, hard hat, or hearing protection used for appropriate conditions will reduce personal injuries.
- c) Avoid accidental starting. Ensure the switch is in the off position before plugging in. Carrying power tools with your finger on the switch or plugging in power tools that have the switch in invites accidents.
- d) Remove any adjusting key or wrench before turning the power tool on .A wrench or a key left attached to a rotating part of the power tool may result in personal injury.
- e) Do not overreach. Keep proper footing and balance at all times. This enables better control of the power tool in unexpected situations.
- f) Dress properly. Do not wear loose clothing or jewellery. Keep your hair, clothing and gloves always from moving parts. Loose clothes, jewellery or long hair can be caught in moving parts.
- g) If devices are provided for the connection of dust extraction and collection facilities, ensure these are connected and properly used. Use of these devices can reduce dust related hazards.

4) Power tool use and care

- a) Do not force the power tool. Use the correct power tool for your application. The correct power tool will do the job better and safer at the rate for which it was designed.
- b) Do not use the power tool if the switch does not turn it on and off .Any power tool that can not be controlled with the switch is dangerous and must be repaired.
- c) Disconnect the plug from the power source before making any adjustments, changing accessories, or storing power tools. Such preventive safety measures reduce the risk of starting the power tool accidentally.
- d) Store idle power tools out of the reach of children and do not allow persons unfamiliar with the power tool or these instructions to operate the power tool. power tools are dangerous in the hands of untrained users.

e) Maintain power tools. Check for misalignment or binding of moving parts, breakage of parts and any other condition that may affect the power tools operation .If damaged, have the power tool repaired before use. Many accidents are caused by poorly maintained power tools.

f) Keep cutting tools sharp and clean. Properly maintained cutting tools with sharp cutting edges are less likely to bind and are easier to control.

g) Use the power tool, accessories and tool bits etc., in accordance with these Instructions and in the manner intended for the particular type of power tool taking into account the working conditions and the work to be performed. Use of the power tool for operations different from intended could result in a hazardous situation.

5)Service

a) Have your power tool serviced by a qualified repair person using only identical replacement parts. This will ensure that the safety of the power tool is maintained.

Warning!The use of any accessory or attachment, other than recommended in this instruction manual, may present a risk of personal injury. Have your tool repaired by a qualified person. This electrical tool is in accordance with the relevant safety requirements. Repairs should only be carried out by qualified persons using original spare parts; otherwise this may result in considerable danger to the user.

APPLICATION

Before plugging in, make sure that the network's voltage and frequency correspond to those indicated on the tool's ratings plate; and that the ON/OFF button did not remain blocked. The tool operated, or is in "ON" position when the trigger(F)is pressed and comes back to the "stop" position when the same trigger is released. Always hold the tool firmly with both hands, with handles(A)and (B), while operating.

It is sometimes necessary to apply force on the point of the drill spindle so that the percussion system may operate otherwise the protection device against off-load operating passes into action. Adopt a moderate workload; the use of too much force alters safety and efficiency.

3) CHANGING TOOLS

Unplug the tool from the power supply, only use drill spindles compatible with the tool.

3-1) Mounting clean the drill spindle before use and lightly oil the special imprint. Pull and turn the lock (C) 180° clockwise. insert the drill spindle (D) in the hexagonal housing, the slot on the lock side. Pull and turn lock (C) 180° anticlockwise. Pull the drill spindle to check that it can only have a translation movement translation of about 3cm .

3-2) Dismantling proceed in reverse order to mounting

4) LUBRICATION-OIL LEVEL

Before completing the oil level, unplug the tool from the 230V network. The oil weir offers autonomy of 20 days based on a continuous use of 3 hours a day. But check the oil level every day .Just before the oil level is no longer visible in the gauge window (G) by holding the tool vertically (the drive spindle downwards) ,proceed to flitting the oil reservoir. Remove the oil gauge (G) with the spanner supplied ,watch out not to damage or loose the gasket. Fill the reservoir with type #40 oil (motor oil) Place the gauge back.

5)CHECK OR CHANGE OF CARBON BRUSHES

These procedures are always done tool unplugged from the 230V network. Checking the carbon brushes is advised after 50 hours of use of the tool. Remove the cover (J) .Remove the carbon-holder cap and remove the brush.

The carbon part should be at least 5mm long. In case of wear or in case of forming of excessive sparks, imperatively change both brushes by carbon brushes with identical characteristics.

6) MAINTENANCE

Check every day the tightening of screws and nuts. Except the procedures described in this manual, this tool needs no specific maintenance. The repair of the tool's inner components is of the competence of specialists.

The cleaning of plastic parts is done with a soft damp cloth and a bit of mild soap. Never submerge the tool and do not use detergents , alcohol, spirit ,etc...For an in-depth cleaning, please consult the after-sales department.

Warning: For maintenance and cleaning, always remove the plug from the electric power supply. Never use water or other liquids to clean electric parts.

3. TECHNICAL CHARACTERISTICS

Power supply: 220-240 V~50 Hz

Power: 1700 W

Percussion frequency: 1850 bpm

Protection: Class II

Weight : 15.6 kg

4. MAINTENANCE

CAUTION: Always be sure that the tool is switched off and unplugged before attempting to perform inspection or maintenance.

Replacing carbon brushes

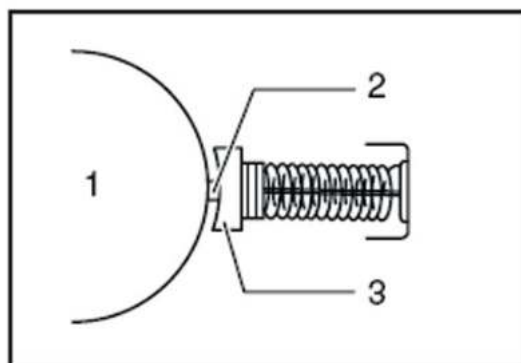

1. Commutator
2. Insulating tip
3. Carbon brush

When the resin insulating tip inside the carbon brush is exposed to contact the commutator, it will automatically shut off the motor. When this occurs, both carbon brushes should be replaced. Keep the carbon brushes clean and free to slip in the holders. Both carbon brushes should be replaced at the same time. Use only identical carbon brushes.

5. ASSEMBLY

CAUTION:

Always be sure that the tool is switched off and unplugged before carrying out any work on the tool.



- 1. flat chisel
- 2. point chisel

To install the bit, follow either procedure (1) or (2) described below.

Lubrication

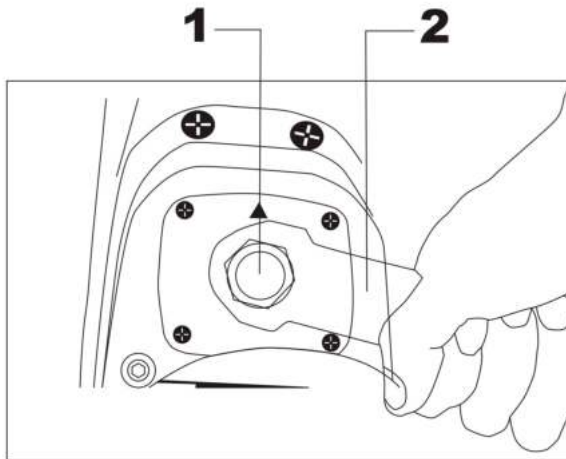

- 1. cap
- 2. wrench

This tool requires on hourly or daily lubrication because it has a grease-packed lubrication system. It should be relubricated after every 6 months of operation. Send the complete tool to LUOBIN Authorized or Factory Service Center for this lubrication service. However, if circumstances require that you should lubricate it by yourself, proceed as follows.

First, switch off and unplug the tool.

Remove the cap using a wrench 23 , then replenish with fresh grease (60g) . Filling with more than the specified amount of grease can cause faulty hammering action or tool failure. Fill only with the specified amount of grease.

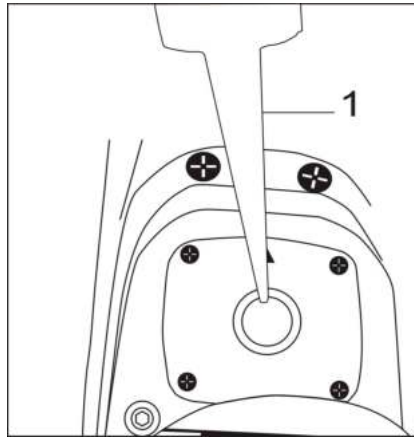

1.hammer grease

Reinstall the cap and secure with the wrench.

To maintain product SAFETY and RELIABILITY, repairs, any other maintenance or adjustment should be performed by LUOBIN Authorized or Factory Service Centers, always using LUOBIN replacement parts



DAEWOO
POWER PRODUCTS

www.daewoopowerproducts.com

Manufactured under license of Daewoo International Corporation, Korea